

Remote Vehicle Tracking & Driver Health Monitoring System Using GSM Modem & Google Maps

Madhuri Unde, Bharat Borkar

*Information Technology Department, Amrutvahini College of Engineering,
Sangamner, (M.S.) India-431005*

Abstract— Around the world, the number of vehicles theft cases has been increasing at an rapid rate whereas the rate of recovery of the stolen vehicles is still minimal. Furthermore, many service provider companies lack proper fleet management system which causes low efficiency of services and reduced profit as the company could not monitor transportation operations. A real-time remote vehicle tracking system is one of the possible solutions to overcome these issues. This paper presents the development of the remote vehicle tracking system which integrates the Global System for Mobile Communications (GSM) Modem and Google Map. The GSM modem at the control centre will receive the coordinates through Short Message Service (SMS) and updates the main database. The information then will be accessed by the website and the position of the vehicle will be displayed through the Google Maps application. A website has been developed to aid the user to track and view the vehicles' location and can be access anytime and anywhere as long as Internet connection is available. The three working functions are the latest tracked vehicle location, route history and route planner. The developed remote vehicle tracking system demonstrates the feasibility of real-time tracking of vehicles, which can be used for many applications including vehicle security and fleet management.

Keywords— GPS, GSM, Vehicle tracking, Google maps

I. INTRODUCTION

In urban life transportation is very common. A lot of mishappenings occur on the road every day .Therefore the need of security and monitoring is developed. To resolve such

Various problems that we face, a system is developed using GPS and GSM technologies and an application is introduced in this research work [4].

Generally we face following problems:

1. In critical condition (when vehicle is stolen), one is confused what to do
2. If one has something expensive and he wants to check it regularly
3. How to monitor the drivers health

All these problems are overcome by this system [4].

The system is composed of two parts, which are portable remote vehicle tracking unit and the monitoring centre. The portable remote vehicle tracking unit consists of Advanced RISC Machines (ARM) with the embedded operating system, GPS and a GSM, temperature sensor and heart bit sensor.

This system has Global Positioning System (GPS) which will receive the coordinates from the satellites among

other critical information. Tracking system is very important in modern world. This can be useful in driver health monitoring, tracking of the theft vehicle and various other applications. The system is microcontroller based that consists of a global positioning system (GPS) and global system for mobile communication (GSM). This project uses only one GPS device and a two way communication process is achieved using a GSM modem. GSM modem, provided with a SIM card uses the same communication process as we are using in regular phone. The system allows to track the target anytime and anywhere in any weather conditions [1].

II. PROPOSED SYSTEM

The proposed work of this paper is to develop a system that can be used with real-time wireless monitoring systems which are designed and implemented through GPS network and are able to record and transmit bio-signals of drivers. The aim of this paper is to provide a health monitoring for the driver at any time and any place and to design a vehicle tracking system using GSM and GPS to provide wireless system for monitoring the parameters of driver are as – Body temperature & Blood pressure.

A. System Architecture

Here there are 2 units in given system

1. Vehicle tracking & driver health monitoring unit
2. Control unit

1. Vehicle tracking & driver health monitoring unit

This unit is placed on the vehicle. It has mainly 2 parts:

- a. Biomedical sensors
- b. GPS + GSM unit.

a. Biomedical sensors:

Here to find the health status of driver I am using a body temp sensor as well as pulse rate sensor.

Driver health indicator:

This unit is placed on the driver. Here the electrodes are placed on various parts of driver. This gives the pulse rate of the driver .This data is then amplified using the instrumentation amplifier. The ARM receives this data and calculates the pulse rate of the driver.

b. GPS+GSM unit:

The GPS is used to log the longitude and the latitude of vehicle which is stored in the μ c memory. The GSM unit sends an SMS to the control station containing the location of vehicle.

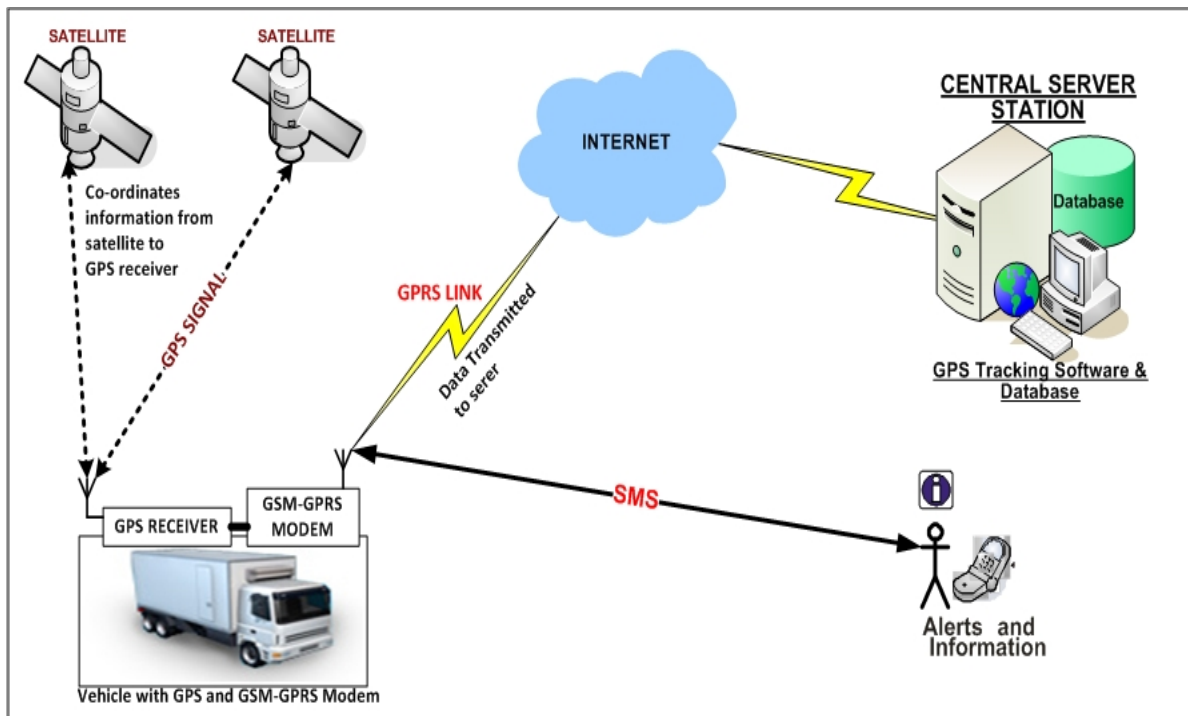

Fig. 1 Architecture of System

2. Control unit-

Upon receiving the SMS, the VB s/w sorts the vehicle's location based on the GPS co-ordinates. In this way the control station can keep a track of all their vehicles. Similarly, control station can also send reply to the corresponding driver through VB screen in terms of SMS. It is necessary for the control station to guide the driver on a correct path if he is lost in the way. The paper has an idea of tracking the vehicle. By using the location sent by the GPS, the control station can understand the position of vehicle (Latitude and Longitude). The base station can access the current status of the vehicle which is displayed on the PC and hence take an immediate action by sending help for the driver or sending backup for the threat ahead

III. DESIGN DESCRIPTION

All the design of proposed system are described in the following.

A. Hardware Description

The main part of system is microcontroller which will access the data. In this paper we will use 'ARM' controller. To measure temperature of driver there will be a temperature sensor. To convert the output of sensor into electrical form we will use signal conditioning (transducer). As controller operates only on digital data, so this analog data is to be converted into digital form by using ADC. But ADC is inbuilt in ARM processor. So the output of the signal conditioner circuit is directly connected to ARM processor.

B. ARM 7- LPC 2148

The ARM7TDMI-S is a general purpose 32-bit microprocessor, offers high performance and very low power consumption. ARM architecture is based on RISC principles, instruction set and related decode mechanism are simpler than CISC Pipeline techniques employed ARM Processor supports both 32-bit and 16-bit instructions via the ARM and Thumb instruction sets. The 3 parameters to be monitored are sensed using respective sensor and data is feed to ARM7. Traditionally, embedded devices include two types of processors: a Microcontroller and a DSP to process signals. However, with the development of ARM processors, last two can be replaced by one single processor. This unit is the

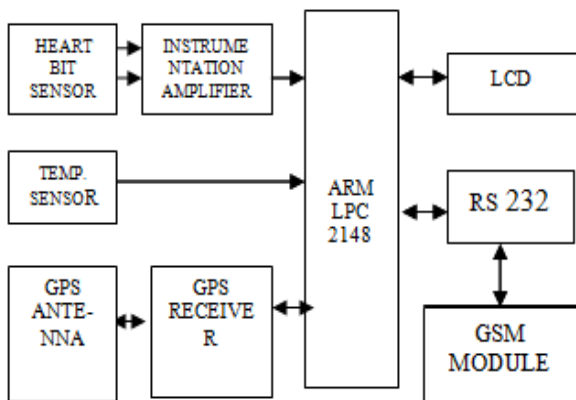

Fig. 2 Block Diagram of System

heart of the complete system. It is actually responsible for all the process being executed. It will monitor & control all the peripheral devices or components connected in the system. In short we can say that the complete intelligence of the project resides in the software code embedded in the ARM 7. The code will be written in Embedded C and will be burned or programmed into the code memory using a programmer.

LPC2148 Micro controller:

LPC2148 Microcontroller Architecture.The ARM7 is a general purpose 32-bit microprocessor, which offers high performance and very low power consumption. The ARM architecture is based on Reduced Instruction Set Computer (RISC) principles, and the instruction set and related decode mechanism are much simpler than those of micro programmed Complex Instruction Set Computers (CISC). This simplicity *results* in a high instruction throughput and impressive real-time interrupt response from a small and cost-effective processor core. Pipeline techniques are employed so that all parts of the processing and memory systems can operate continuously. Typically, while one instruction is being executed, its successor is being decoded, and a third instruction is being fetched from memory. ARM7TDMI-S processor also employs a unique architectural strategy known as Thumb, which makes it ideally suited to high-volume applications with memory restrictions, or applications where code density is an issue. The key idea behind Thumb is that of a super reduced instruction set. Essentially, the ARM7TDMIS processor has two instruction sets:

- The standard 32-bit ARM set.
- A 16-bit Thumb set.

The Thumb set's 16-bit instruction length allows it to approach twice the density of standard ARM code while retaining most of the ARM's performance advantage over a traditional 16-bit processor using 16-bit registers. This is possible because Thumb code operates on the same 32-bit register set as ARM code. Thumb code is able to provide up to 65 % of the code size of ARM, and 160 % of the performance of an equivalent ARM processor connected to a 16-bit memory system [7].

C. Health monitoring

I. Temperature sensor LM35

The LM35 series are precision integrated-circuit temperature sensors, whose output voltage is linearly proportional to the Celsius (Centigrade) temperature. The LM35 thus has an advantage over linear temperature sensors calibrated in ° Kelvin, as the user is not required to subtract a large constant voltage from its output to obtain convenient Centigrade scaling [8]. The LM35 does not require any external calibration or trimming to provide typical accuracies of ±1/4°C at room temperature and ±3/4°C over a full -55 to +150°C temperature range. Low cost is assured by trimming and calibration at the wafer level. The LM35's low output impedance, linear output, and precise inherent calibration make interfacing to readout or control circuitry especially easy

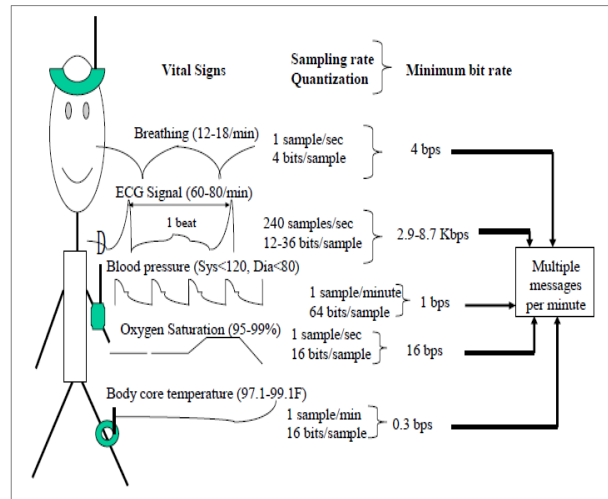

Fig.3 health monitoring functions

II. Heart Bit Sensor

Heart beat sensor is designed to give digital output of heart beat when a finger is placed inside it. This digital output can be connected to ARM directly to measure the Beats per Minute (BPM) rate. It works on the principle of light modulation by blood flow through finger at each pulse.



Fig.4.Non in ipod

The Non in iPod is a digital oximeter and sensor that goes over the user's finger. The unit itself is simply a module that can be readily integrated into a host device. The module measures the blood oxygen level and pulse rate. The oximeter and sensor is contained in a single unit, saving space in the final product. The iPod will be integrated into the system via a 3-wire interface with serial communications, similar to that of the LM92 temperature sensor. Since it is a digital output the unit will interface with the MICA2 via the digital inputs. The iPod has a minimum operating voltage of 2V with a maximum of 6V, thus matching the specifications of our supply voltage of 3V.

D.GPS RECEIVER

Generally message received by GPS is in NMEA [National Marine Electronics Association] message format and NMEA protocol which is most commonly used is NMEA0183 Protocol. GPS sentences beginning with the following specifications: \$GPGGA, \$GPGSA, \$GPGSV, \$GPRMC, and \$GPVTG. And sentences also begins with \$GPMSS.

1) *The Method of Tracking:* The tracking method is based on the process of collecting continuously the coordinate (latitude, longitude) of mobile vehicle that could get from GPS receiver. After getting the coordinate, the mobile vehicle will send it to the supervised center via SMS or GPRS service. The supervised center will receive the coordinate of the mobile vehicle then displays on the screen. The mother board on the mobile vehicle is equipped a GSM modem- GM862 and it is directed by a 32bits microcontroller ARM Cortex M3-LM3S2965. The microcontroller uses serial interface to communicate with GM862 by AT commands and send current position of the vehicle via SMS service by send the sequences commands below:

2) *Commands:*

- AT+CMGF=1<CR>
- AT+CMGS="0937856377"<CR>
- send SMS content : coordinate
- send the message issue Ctrl-Z char (0x1A)
<CR>: carrier return character (0x0D hex)[5].

3) *Applications:*

- Automotive
- Personal/Portable Navigation(PDA)
- Sports and Recreation
- Personal/Portable Navigation (PDA)
- Geographic Surveying
- Ultra low power design (38mA, typical)
- Compact size
- Built-in low noise, high gain active antenna
- Super-cohesive magnetic for installation

4) *Benefits to User:*

- Ultra low power consumption
- Easy and fast to install
- Superior urban canyon performance
- Low cost with high performance

E. GSM HARDWARE

The core of data communication about this system lies in wireless communication control terminals that uses GSM Modules to transfer long-distance data extensively and reliably. It Support instructions of AT commands. SIM300 can be integrated with a wide range of applications. SIM300 is

a Tri-band GSM/GPRS engine that works on frequencies EGSM 900 MHz, DCS 1800 MHz and PCS1900 MHz



Fig. 5. GSM module

IV. SOFTWARE DESIGN

This includes the coding of ARM 7 processor and coding for downloading of data and for GUI (Graphical User Interface) on server side.

For ARM 7 :Embedded c using Keil software.

For GUI :VB.Net

V. ADVANTAGES OF PROPOSED SYSTEM

1. The system is integrated with Google Map to ease users in viewing and locating their vehicle whenever and wherever as long as there is an internet connection (remotely accessible).
2. The system will use the inexpensive Short Message Service (SMS) to transmit the location information.
3. The system is simple and can be easily customized for a variety of applications since it uses the popular Google Map Application Programming Interface (API) and common website programming languages.
4. Tracks latest vehicle position.
5. Tracks latest vehicle Route.
6. Destination and route planner.
7. Driver health monitoring so that we can help drivers in panic situations.

VI. CONCLUSIONS

From the above designed system I can conclude that we are able to transmit the data which is sensed from remote vehicle to the server PC by using wireless transmission technology GPS. It is completely integrated so that it is possible to track anytime from anywhere. It has real-time capability, emerges in order to strengthen the relations among people. The accuracy of system is affected by some factors such as weather, environment around the mobile vehicle and driver unit, GPS receiver, compass sensor and the variation between True North Direction and Magnetic North Direction,etc.

VII .FUTURE SCOPE

There is always chance to improve any system as research & development is an endless process. The following measurements can be done in future”

1. We can optimizing the hardware system, choosing a suitable GPS receiver and compass sensors.
2. Improving the routing algorithm can be improved by neural network.
3. Upgrading this setup is very easy which makes it open to future a requirement which also makes it more efficient.
4. Fuel management
5. Fully integrated system in a box can be developed for commercial purposes.

ACKNOWLEDGEMENT

I would like to express gratitude to my guide Mr.Bharat Borkar for supporting me to do this.

REFERENCES

- [1] Mohammad Ridhwan,Ahemad Faud,Micheal drieborg, "Remote vehicle tracking system using GSM modem and Google maps", IEEE conference on Sustainable Utilization and Development in Engineering and Technology- 2013.
- [2] Ushasree.K, Hameed Pasha, "Protection system for VIP'S with GPRS & Remote monitoring", International Journal of Computer Trends and Technology- volume2Issue2- 2011.
- [3] Rubina.A.Shaikh, "Real Time Health Monitoring System Of Remote Patient Using Arm7", International Journal of Instrumentation, Control and Automation (IJICA) ISSN: 2231-1890, Vol-1 Iss-3,4, 2012.
- [4] Abid khan, Ravi Mishra, "GPS – GSM Based Tracking System", International Journal of Engineering Trends and Technology Volume3 Issue2- 2012.
- [5] Pooja Sathe, "Gprs Based Routing & Tracking Of Mobile Vehicles Using Arm", International Journal of Engineering Research and Applications (IJERA) ISSN: 2248-9622 www.ijera.com Vol. 2, Issue4, July-August 2012, pp.1088-1090.
- [6] Ya-lin Miao†, Xiang-lin Miao, Zheng-Zhong Bian , Yong-jie Zhan "Design and Application of Embedded System Based on ARM7 LPC2104 Processor in Telemedicine", Proceedings of the 2005 IEEE Engineering in Medicine and Biology 27th Annual Conference Shanghai, China, September 1-4, 2005.
- [7] UM10139 Volume 1: LPC214x User Manual, Rev. 01 -15 August 2005, Philips Semiconductors.
- [8] Hui Hu, Lian Fang "Design and Implementation of Vehicle Monitoring System Based on GPS/GSM/GIS" Third International Symposium on Intelligent Information Technology Application ,School of Information Engineering, East China Jiao Tong University, Nanchang, Jiangxi, China in 2009. Pages 278-279.
- [9] Thuong Le-Tien, Vu Phung-The "Routing and Tracking System for mobile Vehicles in Large Area", Fifth IEEE International Symposium on Electronic Design, Test & Applications Dept. of Electrical Electronics Engineering, HCM University of Technology, Vietnam in 2010.