

Review paper on Cognitive Radio Networking and Communications

Ayubi Preet, Amandeep Kaur
*Department of Computer Science and Engineering,
 SGGSWU, Fatehgarh Sahib,
 Punjab, India(140406)*

Abstract-Cognitive radio (CR) is the enabling technology for supporting dynamic spectrum access: the policy that addresses the spectrum scarcity problem that is encountered in many countries. The spectrum sensing problem has gained new aspects with cognitive radio networks. Radio spectrum is the most valuable resource in wireless communication. The cognitive radio and cognitive based networking are transforming the static spectrum allocation based communication systems in to dynamic spectrum allocation. Cognitive radios are intelligent devices with ability to sense environmental conditions and can change its parameters according to the requirements to get the optimized performance at the individual nodes or at network level Thus, CR is widely regarded as one of the most promising technologies for future wireless communications.

Keywords: cognitive radio; dynamic spectrum access; software-defined radio

1. INTRODUCTION

In wireless communication systems, the right to access the spectrum is generally defined by frequency, transmission power, spectrum owner (i.e., licensee), type of use, and the duration of license. Usually, a license is assigned to one licensee, and the use of spectrum by this licensee must be conformed to the specification in the license. In the older spectrum licensing schemes, the license cannot change the type of use or transfer the right to other licensees. Moreover, the radio spectrum is licensed for larger regions and generally in larger chunks. All these factors in the current model for spectrum allocation and assignment limit the use and result in low utilization of the frequency spectrum. Because the existing and new wireless applications and services are demanding for more transmission capacity and more data transmission hence, the utilization of the radio spectrum needs to be improved. [4]

To improve the efficiency and utilization of the radio spectrum, the above mentioned limitations should be amended by modifying the spectrum licensing scheme and adopting a dynamic spectrum management model. The basic idea is to make spectrum access more flexible by allowing the unlicensed users to access the radio spectrum under certain conditions and restrictions. Because the traditional wireless systems were designed to operate on a dedicated frequency band, they are not able to utilize the improved flexibility provided by this spectrum licensing scheme. Therefore, the concept of cognitive radio (CR) emerged, the main goal of which is to provide adaptability to wireless transmission through dynamic spectrum access (DSA) so that the utilization of the frequency spectrum can

be enhanced without losing the benefits associated with static spectrum allocation. The CR is a "smarter radio" in the sense that it can sense channels that contain signals from a large class of heterogeneous devices, networks, and services. On the basis of this sensing, the radio will implement sophisticated algorithms to share the limited-bandwidth channel with other users in order to achieve efficient wireless communication. In this way, the CR concept generalizes the idea of multiple access involving devices in a single homogeneous system to multiple access among devices in different radio spectrums using different radio transmission techniques and hence different systems (i.e., inter-system multiple access as opposed to the more traditional intra-system multiple access), which have different priorities in accessing the spectrum. [4][5]

2. COGNITIVE RADIOS

The term "Cognitive Radio" (CR) was coined by Joe Mitola in 1999-2000, in a number of publications and in his PhD thesis. The term was intended to describe intelligent radios that can autonomously make decisions using gathered information about the RF environment through model-based reasoning, and can also learn and plan according to their past experience. Clearly, such a level of intelligence requires the radio to be self-aware, as well as content and context-aware. [28] [29]

Moreover, Haykin defines CR as a radio capable of being aware of its surroundings, learning, and adaptively changing its operating parameters in real-time with the objective of providing reliable anytime, anywhere, and spectrally efficient communication [28] [29].

The term CR is defined in as follows: "Cognitive radio is an intelligent wireless communication system that is aware of its ambient environment. A cognitive radio transmitter will learn from the environment and adapt its internal states to statistical variations in the existing RF stimuli by adjusting the transmission parameters (e.g., frequency band, modulation mode, and transmission power) in real-time and on-line manner." This definition essentially captures the fundamental concept behind CR. A cognitive radio network (CRN) enables us to establish communications among CR nodes/users. The communication parameters can be adjusted according to the change in the radio environment, topology, operating conditions, or user requirements. Two main objectives of the CR are to improve the utilization of the frequency spectrum and to achieve the highly reliable and highly efficient wireless communications. [5][6].

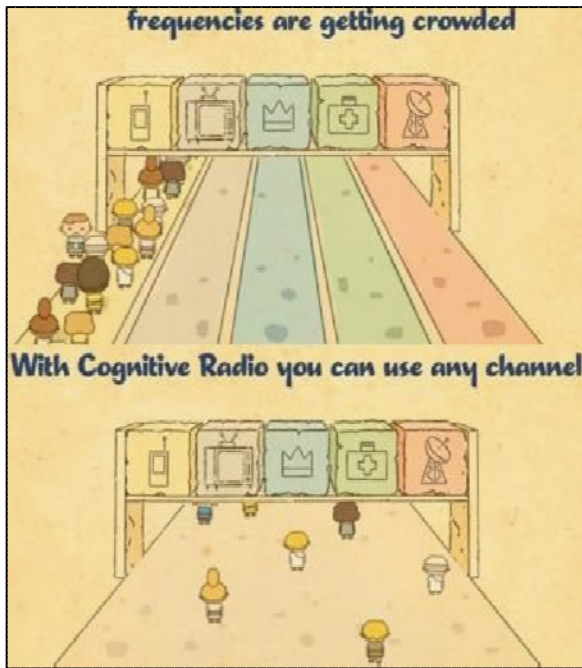

Fig. 1: Frequency utilization in Cognitive Radio Networks. [18]

Cognitive radios are self-aware and intelligent devices which can sense the changing environmental conditions and can change their parameter like frequency, modulation techniques, coding techniques, power etc. according to changing statistical communication environmental thus resulting in efficient utilization of available resources [19]. Cognitive radios must be intelligent enough to learn and decide about their operating parameters and could change their transmission and reception parameters to meet performance requirements and maximize QoS. Operations of the cognitive radio are controlled by the Cognitive engine (CE). The cognitive engine performs the tasks of sensing, analysis, learning, decision making and reconfiguration [22]. Cognitive radio networks consist of two types of users, primary (licensed) and secondary (unlicensed or cognitive) users. Licensed users have higher priority for the usage of the licensed spectrum [26]. On the other hand unlicensed users can opportunistically communicate in licensed spectrum by changing their communication parameters in an adaptive way when spectrum holes are available. [22] [23][24].

Cognitive radio-based DSA or sharing has basically two major flavors, that is, horizontal spectrum sharing and vertical spectrum sharing. In the former case, all users/nodes have equal regulatory status, whereas in the latter case all users/nodes do not have equal regulatory status. In vertical spectrum sharing, there are primary (i.e., licensed) users and secondary (i.e., unlicensed) users, and the secondary users opportunistically access the spectrum without affecting the primary users' performances. Horizontal spectrum sharing can be between homogeneous networks (e.g., IEEE 802.11a operating in the 5-GHz Unlicensed National Information Infrastructure band) or between heterogeneous networks (e.g., coexistence between IEEE 802.11b and 802.15.1 [Bluetooth] networks). When all the networks in a heterogeneous environment have cognitive/adaptive capabilities (i.e., all

coexisting networks have equal incentives to adapt), it is referred to as symmetric sharing. On the other hand, when there is one or more network without cognitive/adaptive capabilities (e.g., coexistence of legacy technology with CR technology), this is referred to as asymmetric spectrum sharing. One example of this is the coexistence of high-speed IEEE 802.11 networks with low-power IEEE 802.15.4 networks. DSA in vertical spectrum sharing is referred to as opportunistic spectrum access. This opportunistic spectrum access is the method for the secondary user to operate within a frequency band that is designated to the primary user. [5] [7]

The concept of Cognitive Radio (CR) appeared as a new paradigm in 1999 as an extension of Software Defined Radio (SDR). It describes the situation where intelligent radio devices and associated network entities communicate in such a manner that they are able to adjust their operating parameters according to the needs of the user/network, and learning from experience at the same time. Since then, there has been a significant amount of effort in the research community on CR-related topics. Standardization activities on Cognitive Radio Systems (CRS) (including TV White Spaces—TVWS) have also been initiated and progressed in many standardization bodies. Almost all regulatory bodies in the USA, Europe and Asia-Pacific regions have acknowledged the importance of CRS on shaping the way spectrum is allocated. [24]

The Fig. 2, described below shows the main building blocks for the deployment of a Cognitive Radio system. In cross layer design of cognitive radio all layers extract information coming from the PHY layer and exchange it to optimize the QoS expectations of the application [27]. CR senses the environment using information from physical and MAC layer. Present protocols designed for the physical and MAC layers for static spectrum allocation cannot be used for the CR based networks. For CR based networks the MAC layer protocols must have the ability to utilize the information from the physical layer. It also helps the MAC layer in assigning the resources to radio nodes. The decisions will be done on the basis of information provided by the Physical layer [23] [25] [26].

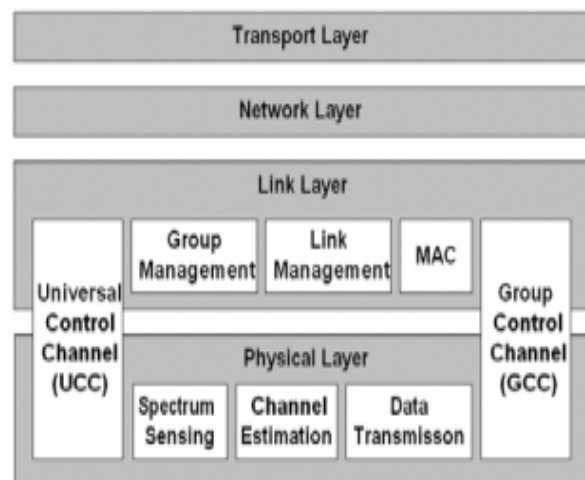

Fig. 2: General ISO/OSI Model for Cognitive Radio [24]

3. CLASSIFICATION:

Depending on transmission and reception parameters, there are two main types of cognitive radio:

- *Full Cognitive Radio* (or Mitola radio): In which every possible parameter observable by a wireless node (or network) is considered. [23]
- *Spectrum-Sensing Cognitive Radio*: In which only the radio-frequency spectrum is considered.[23]

Other types are dependent on parts of the spectrum available for cognitive radio:

- *Licensed-Band Cognitive Radio*: It is capable of using bands assigned to licensed users such as the U-NII band or the ISM band. The IEEE 802.22 working group is developing a standard for wireless regional area network (WRAN), which will operate on unused television channels.[23]
- *Unlicensed-Band Cognitive Radio*: Which can only utilize unlicensed parts of the radio frequency (RF) spectrum. One such system is described in the IEEE 802.15 Task Group 2 specifications, which focus on the coexistence of IEEE 802.11 and Bluetooth. [23]

4. SPECTRUM SENSING METHODS FOR COGNITIVE RADIO

Some of the most common spectrum sensing techniques in the cognitive radio is:

1. Energy Detector Based Sensing:

Energy detector based approach which is also known as radiometry or periodogram, is the most common way of spectrum sensing because of its low computational and implementation complexities. It is more generic method as receivers do not need any knowledge on the primary users' signal. The signal is detected by comparing the output of the energy detector with a threshold which depends on the noise floor. [3]

2. Waveform-Based Sensing:

Patterns known are usually utilized in wireless systems to assist synchronization or for other purposes. A preamble is a known sequence transmitted before each burst and a midamble is transmitted in the middle of a burst or slot. In the presence of a known pattern, sensing can be performed by correlating the received signal with a known copy of itself. This method is only applicable to systems with known signal patterns, and it is termed as waveform-based sensing or coherent sensing. [3][8]

3. Cyclostationarity-Based Sensing:

Cyclostationarity feature detection is a method for detecting primary user transmissions by exploiting the cyclostationarity features of the received signals. Cyclostationary features are caused by the periodicity in the signal or in its statistics like mean and autocorrelation or they can be intentionally induced to assist spectrum sensing. [3] [9]-[11]

4. Matched-Filtering Technique:

Matched-filtering is known as the optimum method for detection of primary users when the transmitted signal is known. The main advantage of matched filtering is the short time to achieve a certain probability of false

alarm or probability of missdetection as compared to other methods. Matched-filtering requires cognitive radio to demodulate received signals. Hence, it requires perfect knowledge of the primary users signaling features such as bandwidth, operating frequency, modulation type and order, pulse shaping, and frame format. [13][3][14]

5. COMPARISON OF VARIOUS SENSING METHODS

A basic comparison of the sensing methods given in this section is presented in Fig. 1. Waveform-based sensing is more robust than energy detector and cyclostationarity based methods because of the coherent processing that comes from using deterministic signal component. However, there should be a priori information about the primary user's characteristics and primary users should transmit known patterns or pilots.

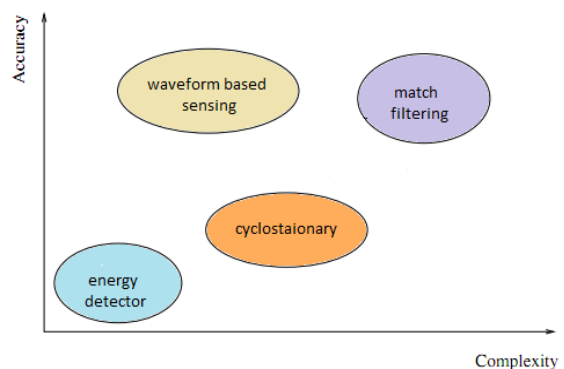

Fig. 3: Main sensing methods in terms of their sensing accuracies and complexities.

The performance of energy detector based sensing is limited when two common assumptions do not hold. The noise may not be stationary and its variance may not be known. Other problems with the energy detector include baseband filter effects and spurious tones. It is stated in literature that cyclostationary-based methods perform worse than energy detector based sensing methods when the noise is stationary. However, in the presence of co-channel or adjacent channel interferers, noise becomes non-stationary. Hence, energy detector based schemes fail while cyclostationarity-based algorithms are not affected. On the other hand, cyclostationary features may be completely lost due to channel fading. It is shown in that model uncertainties cause an SNR wall for cyclostationary based feature detectors similar to energy detectors. Furthermore, cyclostationarity based sensing is known to be vulnerable to sampling clock offsets. [15][16][17][3]

6. CONCLUSIONS

In order to fully utilize the scarce spectrum resources, with the development of cognitive radio technologies, dynamic spectrum sharing becomes a promising approach to increase the efficiency of spectrum usage. Cognitive radio, which is one of the efforts to utilize the available spectrum more efficiently through opportunistic spectrum usage, has become an exciting and promising concept. One of the important elements of cognitive radio is sensing the available spectrum opportunities. In the new spectrum management paradigm, licensed users can share their

spectrum with unlicensed users (referred to as secondary users), thereby increasing the efficiency of spectrum utilization. This method of sharing is often called Dynamic Spectrum Access (DSA).

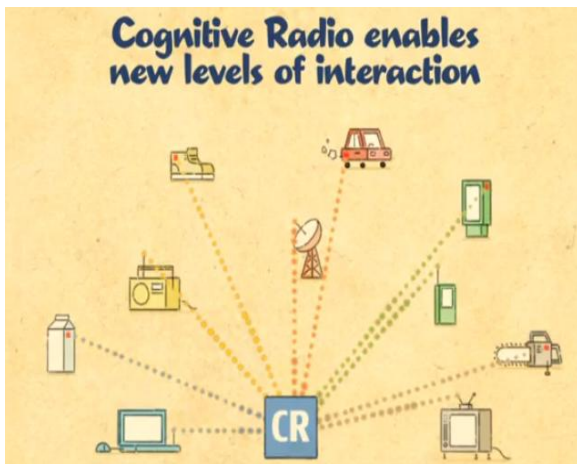

Fig. 4: Cognitive Radio Interaction with other frequencies [19] [30]

REFERENCES

[1] H. Urkowitz, "Energy detection of unknown deterministic signals," *Proc. IEEE*, vol. 55, pp. 523–531, Apr. 2000.

[2] D. Cabric, S. Mishra, and R. Brodersen, "Implementation issues in spectrum sensing for cognitive radios," in *Proc. Asilomar Conf. on Signals, Systems and Computers*, vol. 1, Pacific Grove, California, USA, Nov. 2004, pp. 772–776

[3] Tefvik Yucek et al., "A Survey of Spectrum Sensing Algorithms for Cognitive Radio Applications", *IEEE Communications Surveys & Tutorials*, vol. 11, no. 1, first quarter, 2009

[4] Guest Editorial. *KICS/IEEE Journal of Communications and Networks (JCN) Special Issue on Cognitive radio: A Path in the Evolution of Public Wireless Networks 2008*.

[5] Ekram Hossain, Dusit Niyato and Dong In Kim, "Evolution and future trends of research in cognitive radio: a contemporary survey", *Wirel. Commun. Mob. Comput.* (2013) © 2013 John Wiley & Sons, Ltd., December 2013.

[6] Ashfaqe Ahmed Khan et al, "Research Challenges of Cognitive Radio", *International Journal of Engineering Research & Technology (IJERT)* Vol. 1 Issue 3, May – 2012, ISSN: 2278-0181

[7] Kok-Lim Alvin Yau et al., "Exploring New and Emerging Applications of Cognitive Radio Systems: Preliminary Insights and Framework", 2011 IEEE Colloquium on Humanities, Science and Engineering Research (CHUSER 2011), Dec 5-6 2011, Penang

[8] H. Tang, "Some physical layer issues of wide-band cognitive radio systems," in *Proc. IEEE Int. Symposium on New Frontiers in Dynamic Spectrum Access Networks*, Baltimore, Maryland, USA, Nov. 2005, pp.151–159

[9] U. Gardner, WA, "Exploitation of spectral redundancy in cyclostation-ary signals," *IEEE Signal Processing Mag.*, vol. 8, no. 2, pp. 14–36, 1991.

[10] K. Maeda, A. Benjebbour, T. Asai, T. Furuno, and T. Ohya, "Recognition among OFDM-based systems utilizing cyclostationarity inducing transmission," in *Proc. IEEE Int. Symposium on New Frontiers in Dynamic Spectrum Access Networks*, Dublin, Ireland, Apr. 2007, pp.516–523.

[11] P. D. Sutton, K. E. Nolan, and L. E. Doyle, "Cyclostationary signatures for rendezvous in OFDM-based dynamic spectrum access networks," in *Proc. IEEE Int. Symposium on New Frontiers in Dynamic Spectrum Access Networks*, Dublin, Ireland, Apr. 2007, pp. 220–231.

[12] P. D. Sutton, J. Lotze, K. E. Nolan, and L. E. Doyle, "Cyclostationary signature detection in multipath rayleigh fading environments," in *Proc. IEEE Int. Conf. Cognitive Radio Oriented Wireless Networks and Commun. (Crowncom)*, Orlando, Florida, USA, Aug. 2007.

[13] J. G. Proakis, *Digital Communications*, 4th ed. McGraw-Hill, 2001.

[14] R. Tandra and A. Sahai, "Fundamental limits on detection in low SNR under noise uncertainty," in *Proc. IEEE Int. Conf. Wireless Networks, Commun. and Mobile Computing*, vol. 1, Maui, HI, June 2005, pp. 464–469.

[15] G. Ganesan and Y. Li, "Agility improvement through cooperative diversity in cognitive radio," in *Proc. IEEE Global Telecomm. Conf. (Globecom)*, vol. 5, St. Louis, Missouri, USA, Nov./Dec. 2005, pp.2505–2509.

[16] "Cooperative spectrum sensing in cognitive radio networks," in *Proc. IEEE Int. Symposium on New Frontiers in Dynamic Spectrum Access Networks*, Baltimore, Maryland, USA, Nov. 2005, pp. 137–143.

[17] D. Cabric, A. Tkachenko, and R. Brodersen, "Spectrum sensing measurements of pilot, energy, and collaborative detection," in *Proc. IEEE Military Commun. Conf.*, Washington, D.C., USA, Oct. 2006, pp. 1–7.

[18] [online]. Available: <http://blog.gonzalo-vazquez-vilar.eu/img/blog/nokia-cr.jpg>

[19] Haykin, S., 2005. *Cognitive Radio: Brain-Empowered Wireless Communication*. *IEEE Journal on Selected Areas in Communications*. 23 (2): 201-220.

[20] Huang, Y., J. Wang, H. Jiang, 2010. Modeling of Learning Inference and Decision-Making Engine in Cognitive Radio. In the proceedings of 2010 Second International Conference on Networks Security, Wireless Communications and Trusted Computing, pp: 258 – 261.

[21] Liang, Y.C., Y. Zeng, E.C.Y. Peh, A.T. Hoang, 2008. Sensing Throughput Tradeoff for Cognitive Radio Networks. *J. of IEEE Transactions on Wireless Communications.*, 7 (4): 1326-1337

[22] Ariananda, D.D., M.K. Lakshanan, H. Nikookar, 2009. A Survey on Spectrum Sensing Techniques for Cognitive Radio. In the proceedings of 2009 2nd International workshop Cognitive Radio and Advanced Spectrum Management, pp: 74-79.

[23] M. T. Mushtaq et al, 2013. Cognitive Radios and Cognitive Networks: A short Introduction . In the ISSN 2090-4304 *Journal of Basic and Applied Scientific Research*, pp: 56-65

[24] Boyd, J., *John Boyd Compendium*, [Online]. Available: http://dnipogo.org/john-boyd/link.springer.com/chapter/10.1007%2F978-94-007-1827-2_1.

[25] Reed, J., C. Bostian, 2006. Understanding the Issues in Software Defined Cognitive Radio," in *Dyspan*, Dublin, Ireland.

[26] Stuntebeck, E., T. O'Shea, J. Hecker, T. C. Clancy, 2006. Architecture for an Open-Source Cognitive Radio. In the proceedings of 2006 SDR Forum Conference.

[27] Shankar, S.N., 2007. Squeezing the Most Out of Cognitive Radio: A Joint MAC/PHY Perspective. In the proceedings of 2007 IEEE International Conference on Acoustics, Speech and Signal Processing, pp: 1361-1364.

[28] Available: <http://www.ctr.kcl.ac.uk/crblog/CR.html.web.it.kth.se/~maguire/jmitola/>

[29] S. Haykin, "Cognitive Radio: Brain-Empowered Wireless Communications", *IEEE Journal on Selected Areas in Communications*, Vol. 23, NO. 2, Feb. 2005, pp. 201-220

[30] *Cognitive Radio Images* [Online]. Available: <http://mynokiablog.files.wordpress.com/2010/06/nok.jpg>